

Much More than a boat or a house,
SeaLoft® is a place to live on water.

"PANORAMA" MODEL

48 m²* of living space on the water ...

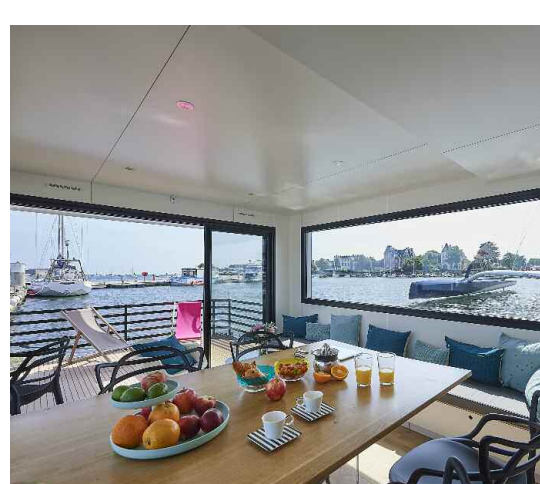

Specially designed and adapted to the stay of a 3 to 5 persons family, this "Panorama" model has a 360° view bedroom on the 2nd floor and an optional 20 m² terrace.

Eco-friendly design, recyclability, durability, comfort.

Its superstructure is an eco-designed wood frame house providing all the advantages of this material: longevity, recyclability, controlled hygrometry, almost no thermal bridge, great thermal and acoustic comfort. The insulation of the building is made of wooden wool.

The large main room, kitchen / living room, largely lit on 3 sides, opens onto a terrace and creates a beautiful 25 m² living space on the water.



In its basic version the boat is equipped with all its comfort functions: 2 burners hob, 2 kW Bio Ethanol heater, 60 L water heater, electronic marine toilet with water optimized management, drinkable and waste water tanks.

In autonomy in respect of the environment

The SeaLoft can be used in connected mode at the dock or the river banks. It then receives electrical energy directly from the land network, and wastewater is discharged to the sewage network.

To allow life at anchor in open water, the SeaLoft is equipped with large capacity tanks, both for fresh water, and for sewage (black water from toilets and gray from dishes and bathroom). The boat can be equipped with electric (or thermal) propulsion and the 16 m² roof top of can receive 2.9 Kw capacity solar panels.

* 48 m²: lower terrace included, upper terrace excluded.

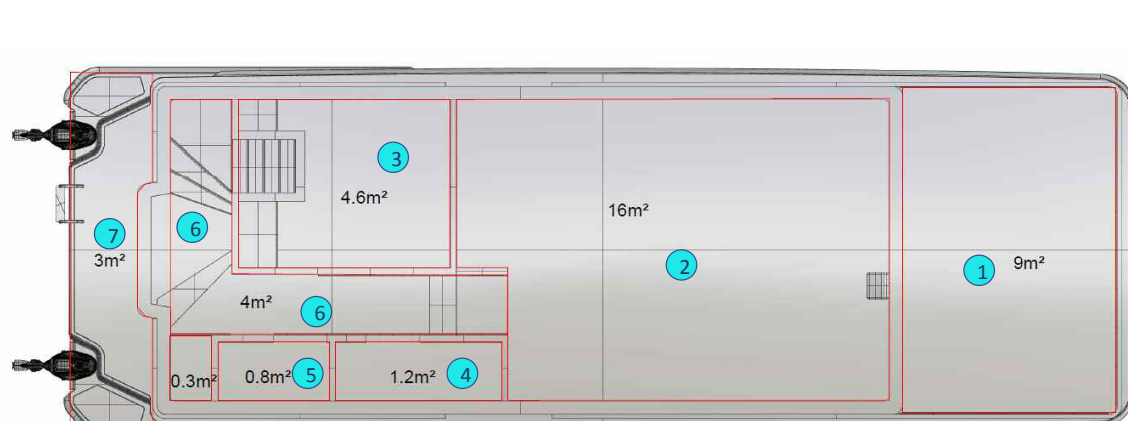

LOWER DECK

- 1 External terrace: 9 m²
- 2 Living Room - Kitchen: 16 m²
- 3 Bedroom: 4,6 m²
- 4 Bathroom: 1,2 m²
- 5 Toilets: 0,8 m²
- 6 Internal runway: 4 m²
- 7 Doorstep on boat stern: 3 m²

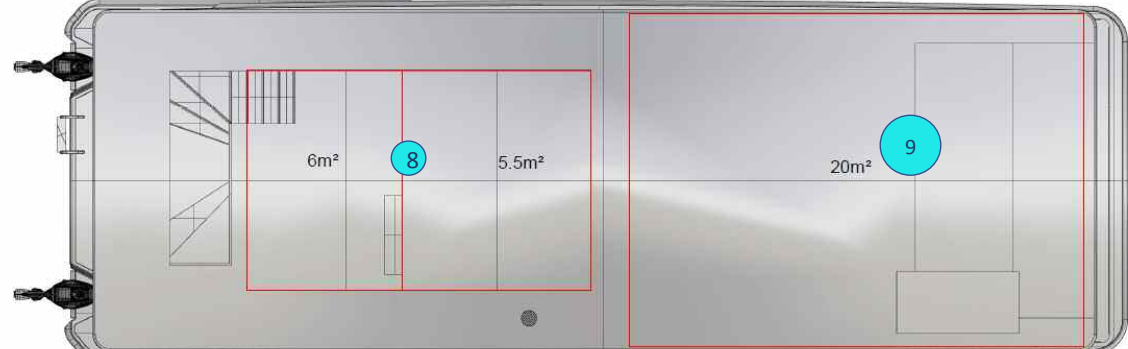

UPPER DECK (with terrace in option)

- 8 Bedroom upper floor: 11,5 m²
- 9 Terrace upper floor: 20 m² (optional)

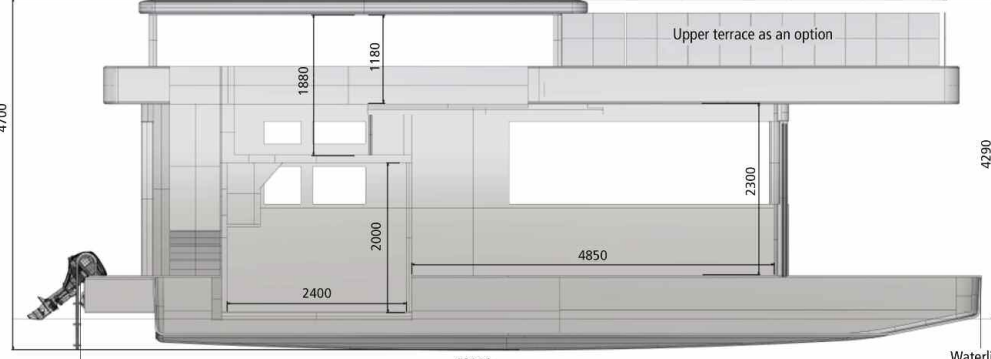

SECTIONAL VIEW (with upper terrace option)



FRONT VIEW (with upper terrace option)



A level of quality to withstand the aggressions of the marine environment.

The SeaLoft is CE marked in accordance with the Leisure boat European Directive 2013/53 / EU and designed for the D * Navigation Category.

Particular care in the choice of materials and manufacturing processes gives the boat a high level of quality standard, able to withstand the aggressions of the environments in which it will navigate.

Optional built-in home automation for the boat management.

A complete home automation system optimizes the security and the SeaLoft management. The boat is equipped with wireless sensors that transfer information to a mobile app, tablet or PC.

Intrusion detection (safety)	Drinking water and waste water tank level
Water flooding detection in the boat holds (safety)	Dock water consumption
	Dock electricity consumption
Smoke detection (safety)	Battery energy level detection

The SeaLoft manager visualizes this data in real time on his application screen (tele transmissions are carried out by a 4G chip).

FEATURES INCLUDED IN BASE PRICE	
<ul style="list-style-type: none"> • 2 burners hob • 130 L, 12 v stainless steel fridge • 2kW bioethanol heater • Drinking water tanks (2 x 600 Liters) • Black water tank (208 L) • Brackets for mounting 2 x 10 kW electric outboard engine or 2 x 25 Hp outboard engines. • Hull protection blade for boat grounding • 60 L 1200 W 230 V water heater • Interior led spotlight and tapes • Electric Marin toilets with water management • 3 x 100 Ah domestic battery bank with Cristec 40 A battery charger 	<ul style="list-style-type: none"> • Windows: double glazing, Aluminum marine quality painting window frames • 230 V socket outlets (4 in living room, 3 in kitchen, 1 in bathroom, 2 in main bedroom, 1 in kids bedroom). • 1 Grey water tank 600 L (2nd 600 L tank in option) • USB socket outlets (4 double outlets in main bedroom, 2 in kid's bedroom, 1 in kitchen) • Navigation and mooring lights • 6 mooring cleats • Mooring lines • 3 x 2 KG Fire extinguisher • Power outlet + electric cord extension
OPTION	
<ul style="list-style-type: none"> • 20 m² upper terrace • Boarding ladder • Oven + 2 gas burner hob • 2nd grey water tank • 2 Torqeedo 10 kw outboard engine + 4* High capacity Lithium 2 685 Wh battery pack • 2 x 25 Hp Yamaha outboard engines 	<ul style="list-style-type: none"> • 12/24 V LED/DVD 22" combo set + antenna • Anchor locker + bowroller + mooring lines + 1000 W windlass • Bow thruster • Full Home automation system • Full safety kit (life jackets, horse shoe buoy, ...) • 16 m² Solar panels, 2,9 kw